

Edificio Fórum in Barcelona

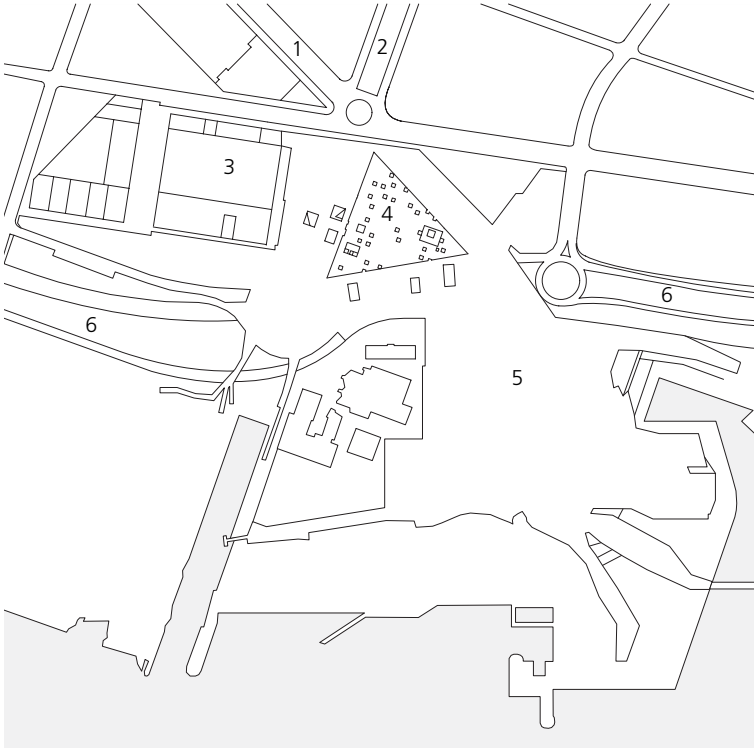

EDIFICIO FÓRUM IN BARCELONA



Site plan scale 1:10000

- 1 Avenida Diagonal
- 2 Rambla de Prim
- 3 Congress centre
- 4 Edificio Fórum
- 5 Explanada del Fórum
- 6 La Ronda Litoral

As part of an urban regeneration project in Barcelona, the local authority set itself the ambitious goal of restructuring and reinvigorating a long neglected district in the east of the city, not far from the mouth of the Besòs. In 2001 work began on turning this 'no-man's-land' – a derelict industrial site with sewage works and power station, surrounded by 1960s tower blocks – into a new and lively urban district.

An artificial platform, some 15 hectares in extent, was built over the wide coastal highway, La Ronda Litoral, and the surviving industrial plant below, to open up access to the sea for inhabitants and visitors alike. This new area, called the Explanada del Fórum, now provides a fitting conclusion

The flat, triangular building seems to float above the Explanada del Fórum, forming a protective canopy for outdoor events and activities.





The ultramarine-blue façade of the upper storey is pierced by sharp incisions and irregularly shaped windows.



to the Avenida Diagonal, a main road that pierces Ildefonso Cerdà's otherwise strictly orthogonal urban plan of 1859.

The main feature on the Explanada del Fórum is the Edificio Fórum, designed by the Swiss architects Herzog & de Meuron. Their triangular-plan lecture, concert and exhibition building is the architectural symbol of this new urban district. Also on the site are hotels, office blocks and a congress centre, enlivened by a range of themed outdoor spaces. The first event to be held in the Edificio Fórum was the 'Universal Forum of Cultures', which took place between May and September 2004, attracting over three million visitors.

At the seafront end of the Avenida Diagonal a new events site was built on a raised platform. The Edificio Fórum forms the focal point of this space.

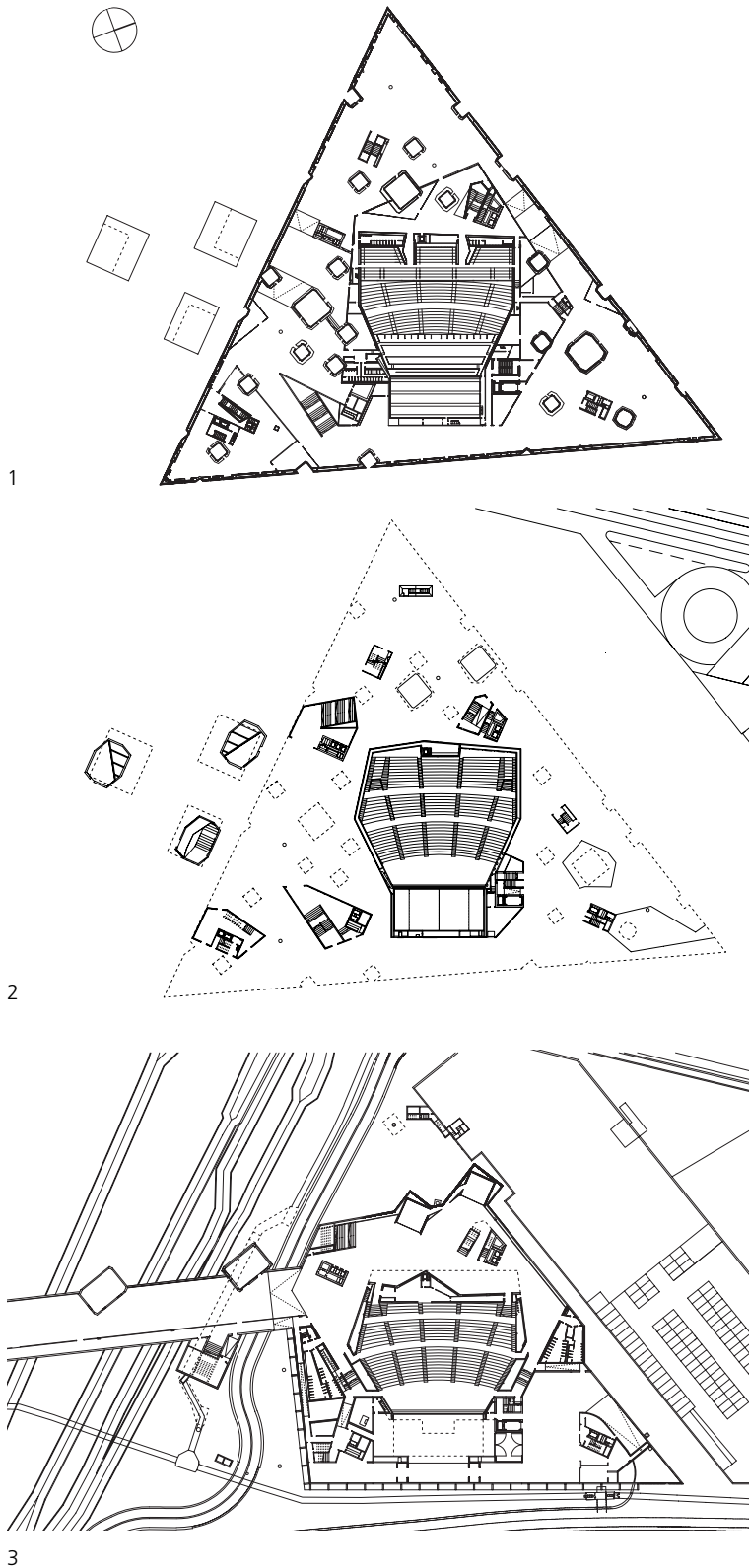

The triangular outline of the Edificio Fórum, each side roughly 180 m in length, continues the axes of the Avenida Diagonal and the Rambla de Prim. The building seems to float above the Explanada del Fórum, forming a large covered space for open-air activities. Because of the history, climate and culture of Barcelona, outdoor space here is regarded as a place for social encounter, a place for people to meet and interact. Recognising this, the architects wanted the design of their building to promote and structure this aspect of city life. Also, in order to optimise function, flexibility and spatial relations, they decided on a horizontal arrangement of space, accommodating an auditorium, exhibition areas, small offices and a restaurant with access to the roof terrace.

The upper storey of the Edificio Fórum, providing about 8,000 square metres of exhibition space, is wrapped in an ultramarine-blue façade. The coarse-texture spray-on render, of the kind that is also used in tunnel construction, contains luminous blue colour pigments which, depending on the angle of incident light, can make the façade appear blue, violet or sometimes almost black. The building skin is pierced by irregularly shaped reflecting window slits and sharp incisions.

Floor plans scale 1:2500

- 1 Exhibition level
- 2 Level of main square, with access to exhibition areas and auditorium
- 3 Basement with foyer and connecting corridor to the adjacent congress centre

The Explanada del Fòrum flows under this first floor, interrupted occasionally by glazed entrances leading into the extensive, underground foyer and to the exhibition rooms. The auditorium, with seating for 3,200, stretches from the basement to up under the roof. Direct contact with the covered open-air space, i.e. the public areas, is ensured by extensive glazing on the side walls of the ground floor. Below ground the auditorium is connected to Josep Lluís Mateo's Barcelona International Convention Center by a column-free tunnel with a 20-metre free span.



The underside of the first floor of this large blue building is clad with stainless steel panels. Embossed on these panels is a pattern imitating the reflecting surface of water.



The stainless steel cladding seen outside continues in the auditorium on the underside of the balcony. The panels here have been coloured blue in an electrolytic process.

Embedded in a square that rises gently towards the sea, the jutting shape of the Edificio Fòrum looks like a large tectonic plate, a building that is at the same time a topographical feature. To realise this design idea, a 4-metre-high space frame was built, on a 6 x 6-metre grid. This forms the primary support structure for the upper floor. Tension

cables were used to give additional stabilisation. Shear walls, services and communications cores are designed with sliding connections to the floor, while five slim columns provide fixed support. Suspended from the main girder, 12-metre-high vertical trusses form the support frame for the outer façade. These in turn support the 0.85-metre-

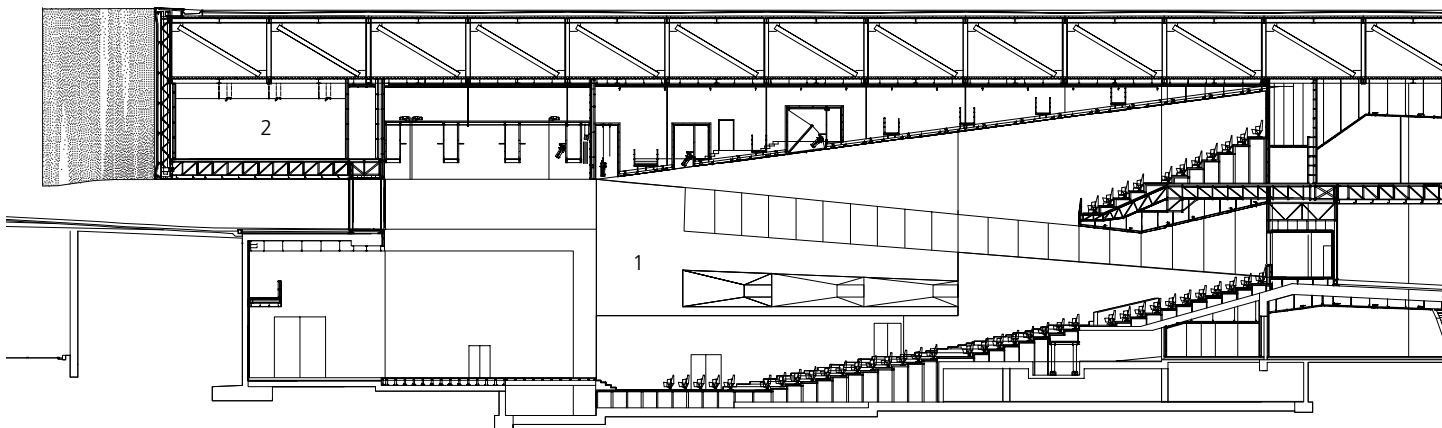

deep beams which carry the floor of the exhibition rooms. The underside of the floor is clad with polished and embossed stainless steel sheet.

A number of glazed light wells penetrate the upper storey, giving rise to a diverse pattern of interconnections between the building and the outside space. These many-sided shafts are clad with a continuation of the stainless steel found on the underside of the building, making them look like faceted gemstones. Each light well, or patio, has a

different theme, e.g. a marketplace with fountain or a small chapel clad with gold-coloured stainless steel sheet. The overall effect is to enliven and enrich the space. Daylight pours through the glazed lanterns into these spaces, providing natural illumination in the first-floor level exhibition areas and marking out the entrances to exhibition rooms, auditorium and restaurant. The complex geometric form of the light wells derives from the interplay of the axes from Cerdà's plan and the Avenida Diagonal.

Broad expanses of glass and the use of stainless steel panelling on ceilings inside and out give an impression of continuous space.

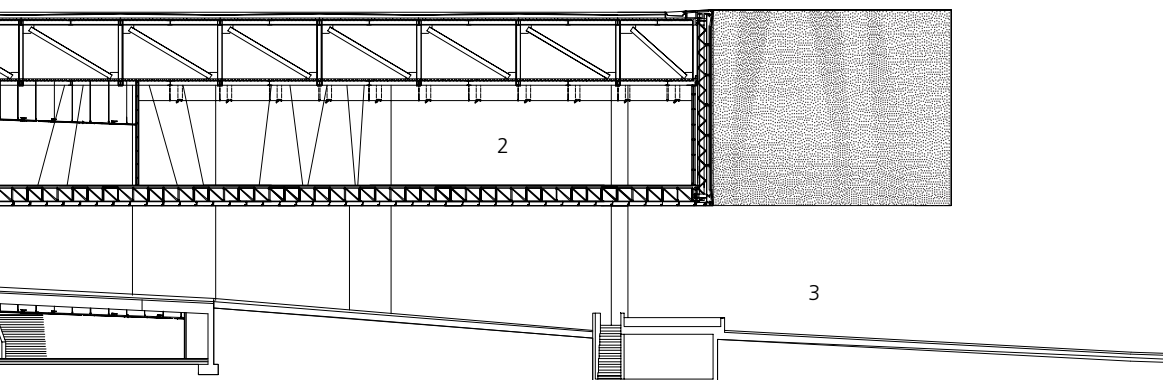

Longitudinal section
scale 1:500
1 Auditorium
2 Exhibition area
3 Explanada del Fórum

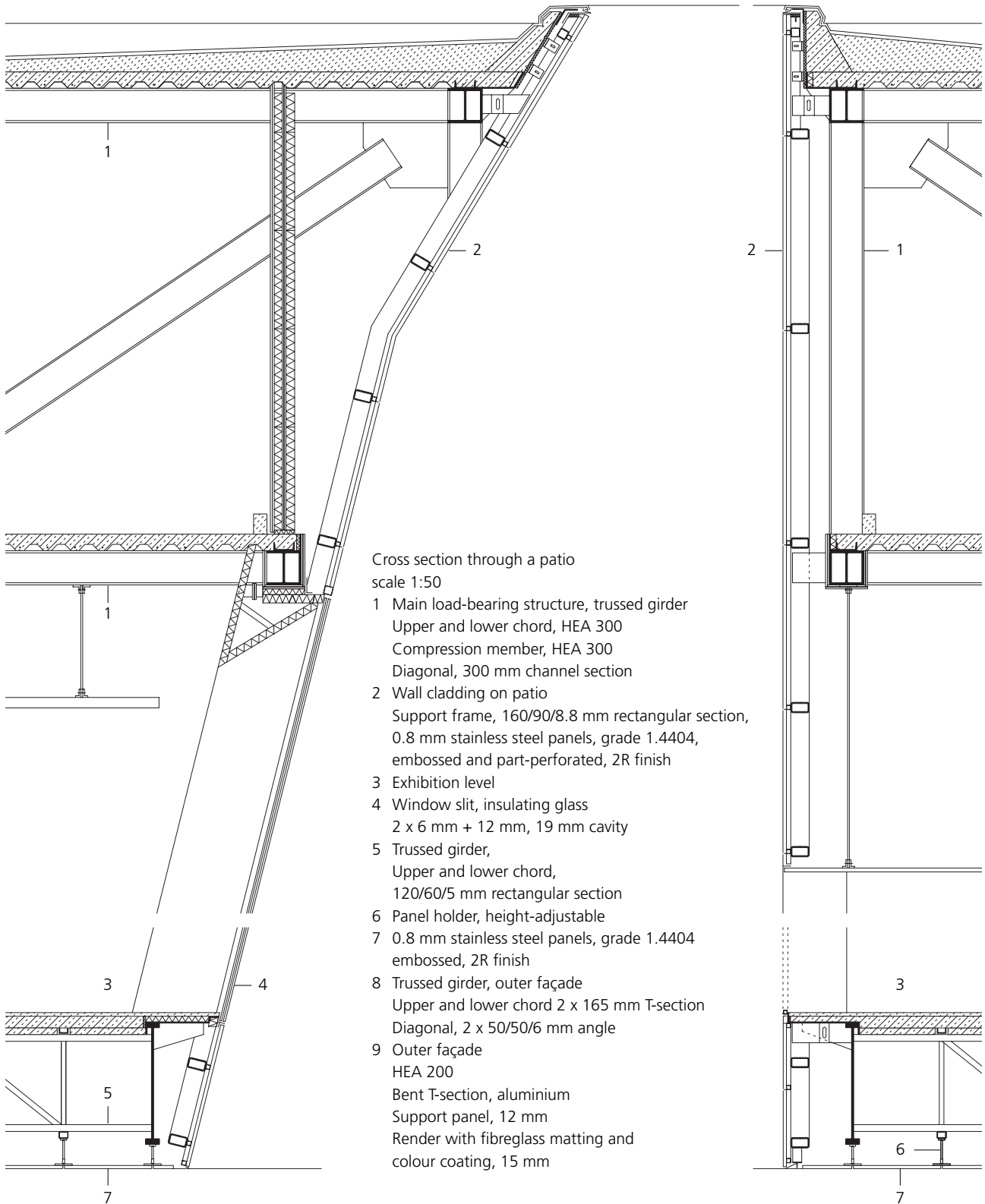

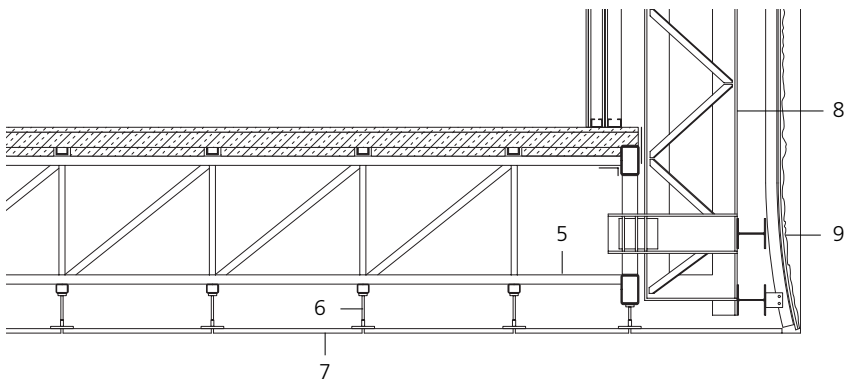
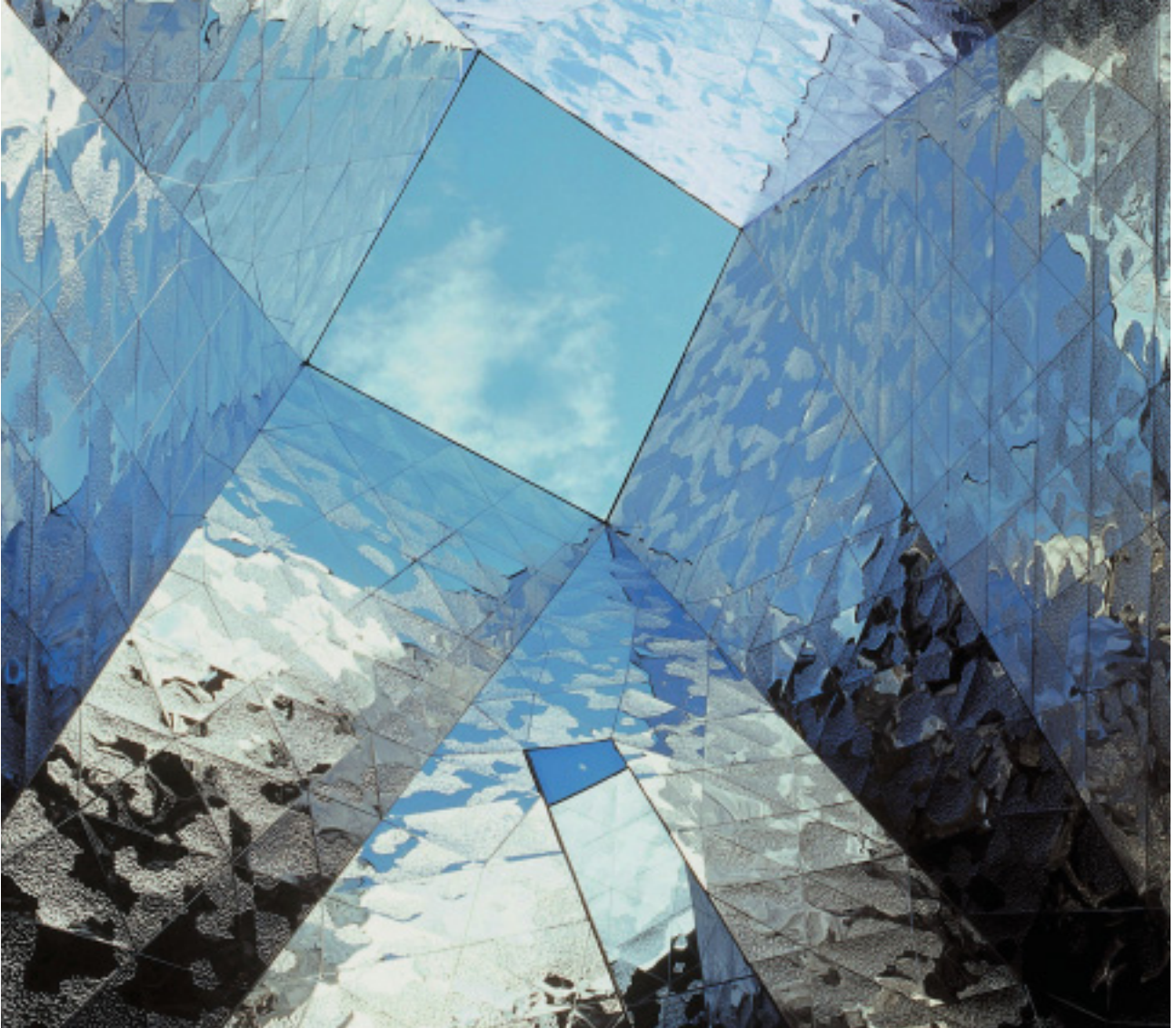

The changing light and cloud patterns are reflected many times over in the angled surfaces of the shaft walls.

In total over 28,000 different stainless steel panels were fitted, each triangular in shape, with sides of around 1.10 metres in length. Most of the panels were used to clad ceilings, but some were used on walls, e.g. in the patios. Each panel is different. The embossing patterns for the irregular triangles are based on a mathematical model of a real water surface. Imaging and construction data were fed into a control program for the metal-finishing machine. This machine



A specially developed fixing system gives great flexibility in fitting together the panels.

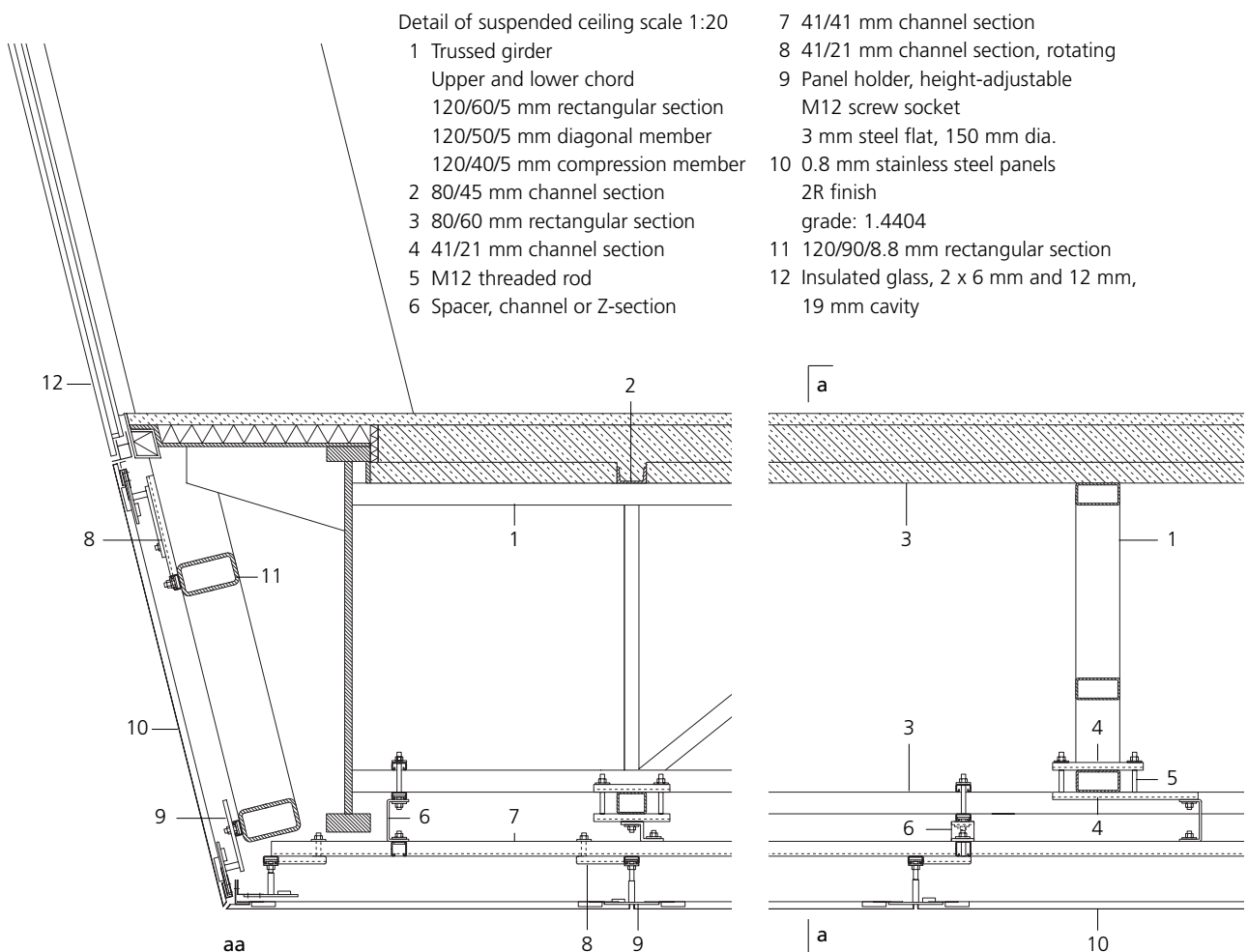



The embossing pattern on the stainless steel sheet, applied in a computer-controlled process, is based on a real photograph of the surface of water. Each panel is embossed with a different design, all the different patterns combining to create the overall picture.

In the light wells the triangular panels were placed carefully to ensure the embossing pattern continued smoothly around the walls of the shaft.

impressed a pattern imitating the texture and rippling of waves onto the stainless steel, using tools of different diameters.

The pattern on one panel continues on the adjacent panel. However, because the individual panels not only differ in terms of pattern, but also in their dimensions, a very flexible fitting system was developed specially for this project. In addition, the junctions are designed in such a way as to take not only six, but in some cases seven or eight triangular corners.

Over 140 tonnes of stainless steel (grade: 1.4404) were used in the Edificio Fòrum. Grade 1.4404 is an alloy containing chromium, nickel and molybdenum. It has good resistance to the salty, corrosive atmosphere found in coastal locations. As an austenitic stainless steel it is also easy to form and weld. The surface of the bright annealed material (2R) is also additionally mechanically polished.

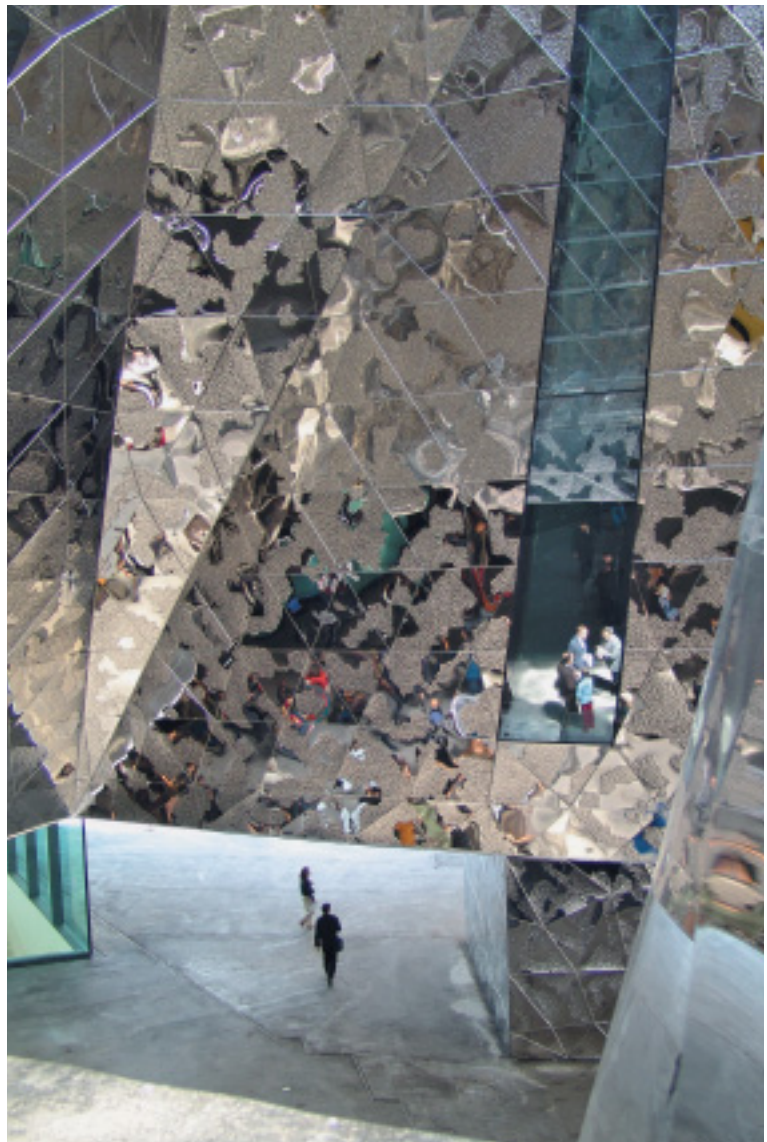

The Edificio Fórum is a highly distinctive building that is already viewed as the symbol of this 'new' urban district. For the architects, implementing their innovative ideas and this distinctive vocabulary of shapes also entailed developing new techniques. There are many examples of metal façades made up of a wide range of differently sized panels. But the Edificio Fórum in Barcelona is the first to employ a continuous embossed pattern stretching across more than 14,000 square metres of individually designed stainless steel panels.

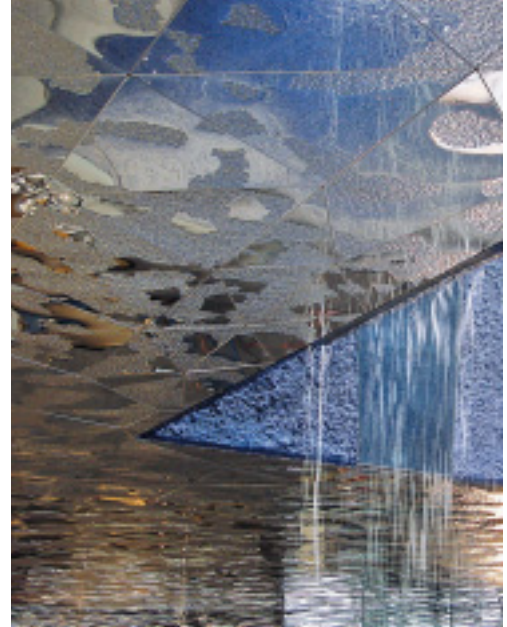

Water was not only the inspiration behind the embossing pattern on the stainless steel sheet, it is also found on the roof, in a reflecting reservoir, and in one of the courtyards, in the form of a small waterfall.

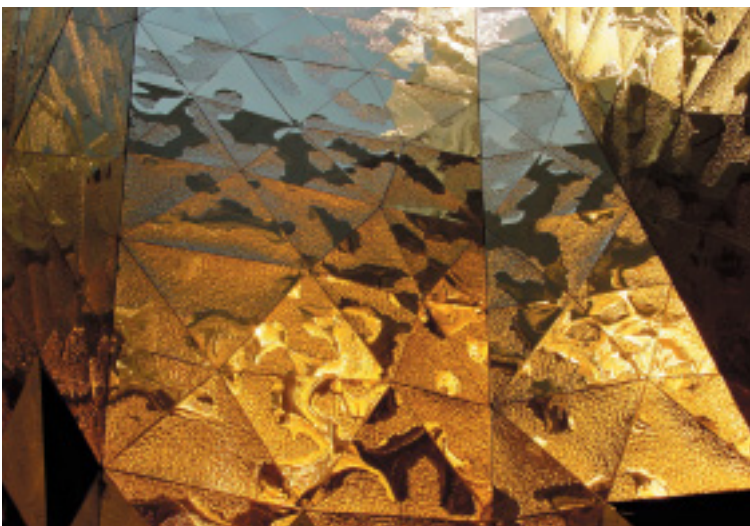

In the small chapel, the embossed triangular stainless steel panels have an appropriately dignified golden gleam. The finish was achieved by vapour deposition with titanium nitrate.

Euro Inox
Diamant Building, Bd. A. Reyers 80,
1030 Brussels, Belgium
Phone +32 2 706 82 67
Fax +32 2 706 82 69
E-mail info@euro-inox.org
Internet www.euro-inox.org

Client: Ayuntamiento de Barcelona,
Infraestructuras del Llevant de Barcelona S.A., Spain
Architects: Herzog & de Meuron, Basel, Switzerland
Text and Layout: circa drei, Munich, Germany
Translation: Ingrid Taylor, Munich, Germany
Photos: Monika Nikolic/artur, Cologne, Germany
(cover, p. 1, p. 2 bottom, p. 4 bottom, p. 6, p. 8)
Infraestructuras del Llevant de Barcelona, Spain (p. 2 top)
Reuters AG, Berlin, Germany/Albert Gea (p. 4 top),
Iñigo Bujedo Aguirre, Barcelona, Spain (p. 5)
Inox-Color/Detlef Schobert, Walldürn, Germany
(p. 9, p. 10, p. 11)